

WHITE PAPER

# Leaving Money on the Table: The Untapped Value of Solar+Storage

by Jon Newman and Dr. Amir José Daou Pulido

## Introduction

As the lowest-cost source of generation in most power markets, solar energy is expected to triple in the next 10 years with 1 TW of photovoltaic (PV) power plants coming online.<sup>1</sup> Along with efforts to retire existing thermal generation and limit the construction of new thermal power plants, increasing solar penetration will necessitate more flexibility in power markets. The need to provide firm, reliable energy and the declining value of mid-day generation will drive energy storage's continued growth. Solar + Storage pairings are positioned to deliver both clean energy and flexibility to the grid.

Adding co-located<sup>2</sup> storage to a solar PV system can deliver new areas of economic value, yet the broad range of additional revenue streams and benefits from such systems is often underestimated or ignored.

Capturing the full value of Solar + Storage requires consideration of five distinct value streams:

1. Energy Shifting
2. Firm Power / Risk Mitigation
3. Merchant Trading / Flexibility Services
4. Integration of Renewables
5. Incentive Capture

The goal of this white paper is to help asset owners better understand and consider all five categories to maximize the value of their projects. The economic objectives of a Solar + Storage influence and in part direct system design, sizing, and configuration. A refresher on AC vs. DC-coupled configurations is included on the next page.

<sup>1</sup> BNEF 2020 Long-Term Energy Storage Outlook. [Subscription required].

<sup>2</sup> For the purposes of this white paper, "co-located" is broadly defined to include Solar + Storage projects that share a point of interconnection and those that do not.

## AC V. DC COUPLING:

# A Refresher

There are many advantages and drawbacks to both configurations – the optimal solution is often driven by economic and technical objectives and system limitations, as well as market design and regulation.

### AC-COUPLED, CO-LOCATED

Separate inverters for the solar array and the battery

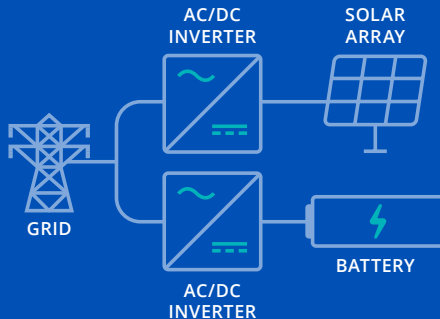

The solar and energy storage are located at the same site and either share a single point of interconnection to the grid or have two separate interconnections. However, the solar and storage systems are connected to separate inverters, and the energy storage is sited adjacent to the solar project.

### DC-COUPLED, CO-LOCATED

Single inverter for the solar array and the battery

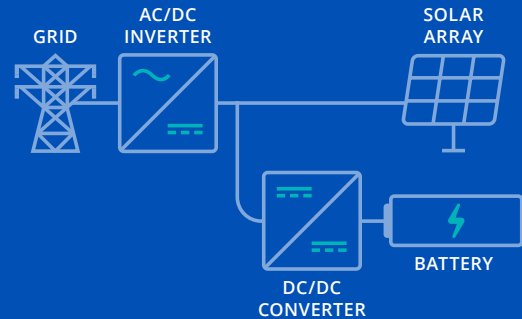

The solar and energy storage are located at the same site and share the same interconnection. In addition, they are connected on the same DC bus and use the same inverter. A DC/DC converter connects the storage asset to the solar asset. In DC-coupled configurations, the storage system is distributed throughout the solar project site.

## A Broad Range of Value

In many markets, Solar + Storage configurations will dominate energy storage deployments. For example, in the United States, analysts project that over 50% of deployed energy storage capacity (MW) in the next five years will be co-located with solar PV.<sup>3</sup> The U.S. is far from alone in that regard; Fluence also expects 60-90% of energy storage deployed to be paired with solar in emerging markets such as Israel and India, as well as across Southeast Asia.

Solar + Storage offers a broad range of benefits to asset managers. Compared to standalone energy storage and solar PV resources, co-located resources can take advantage of revenue and cost synergies, increasing the combined asset's value in the market.

### CAPTURING ALL VALUE STREAMS

Solar + Storage is most often deployed as a tool to time-shift solar energy into the evening peak, providing firm solar output even after the sun has set. While this is a highly valuable application of the combined asset, the full value of Solar + Storage is much broader.

At Fluence, we work to help customers access the broad range of value our energy storage solutions can provide to them. For Solar + Storage applications, we have found the value energy storage provides is multifaceted. Most customers stack multiple value streams together to deliver a robust asset return and economic outlook from energy storage; co-located solar and storage assets should be no different. The table below breaks down the value Solar + Storage is well equipped to capture, each providing a unique revenue stream that can be aggregated.

<sup>3</sup> Wood Mackenzie Power & Renewables, U.S. utility solar-plus-storage: The rise of hybridization, August 2020 [Subscription required].

## Solar + Storage Value Streams



### 1. ENERGY SHIFTING

Store and redispatch (time-shift) excess renewable energy from low-price, high-renewable periods (e.g., midday) to peak periods to provide flexible peaking capacity. Drivers are either curtailment due to grid congestion issues or clipping due to solar  $MW_{DC}$  oversizing.



### 2. FIRM POWER / RISK MITIGATION

Mitigate merchant risk exposure due to time specific PPA requirements, retail demand exposure, or broad generation fleet optimization by providing firm energy during high-risk periods.



### 3. MERCHANT TRADING / FLEXIBILITY SERVICES

Charge during low-cost periods and discharge during high-value periods across wholesale energy markets and ancillary service markets such as frequency regulation.



### 4. INTEGRATION OF RENEWABLES

Smooth variable renewable energy output to minimize voltage stability issues, reducing curtailment and limiting mandated transmission and distribution upgrades. In certain markets, such as India or Australia, this includes meeting strict interconnection requirements imposed on intermittent generation including the supply of synthetic inertia and localized frequency regulation.



### 5. INCENTIVE CAPTURE

As public pressure grows to accelerate the energy transition, many markets will increasingly introduce incentives for Solar + Storage, at times impacting the design of the system.

## A Five Point Checklist to Maximize Asset Potential

Given the myriad benefits co-located assets are capable of capturing, it is essential for asset developers, owners, and managers to consider how to maximize system potential. Failing to consider the full suite of value streams risks leaving proverbial – and literal – “money on the table”.

The five steps below, each mapping to a value stream from the table above, provide a range of decisions and actions that must be considered to ensure project owners capture all applicable value streams and utilize their system to its fullest capability.

### THE CHECKLIST

1. Reduce Clipped and Curtailed Energy through Optimized System Configuration
2. Manage Risk Exposure
3. Digital Optimization to Capture Full Benefits
4. Integrate Renewables and Meet Interconnection Value
5. Meet Policy and Regulatory Requirements to Capture Additional Value

**FIGURE 1.** Maximizing 100 MW<sub>AC</sub> Solar Only Versus Solar + Storage Project. *Example Solar Generation with DC-coupled Energy Storage.*

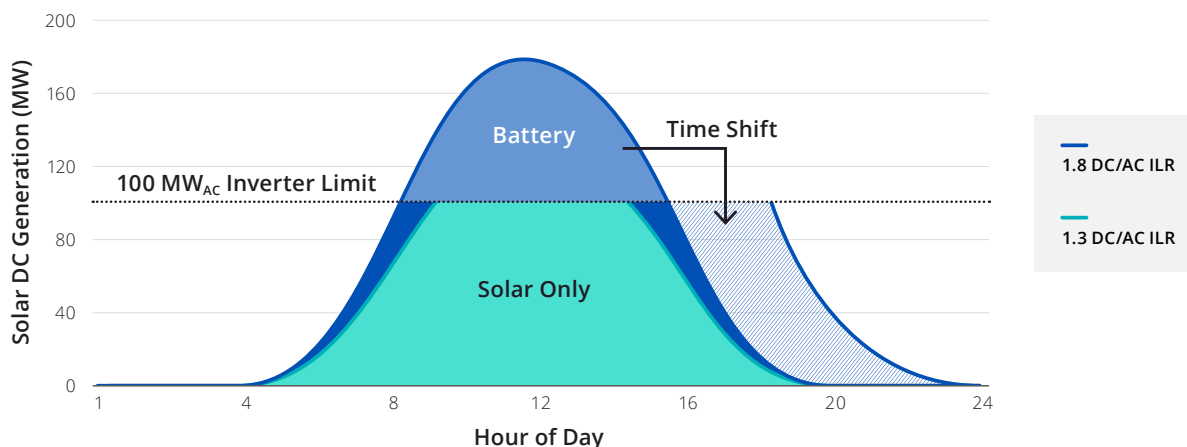

**STEP 1: REDUCE CLIPPED AND CURTAILED ENERGY THROUGH OPTIMIZED SYSTEM CONFIGURATION**

Energy storage can directly increase the revenue generated by a solar asset by capturing excess solar generation and shifting it to a period of high demand. As solar penetration increases in a market, the risk of curtailment – reduced solar generation due to oversupply in a specific location at a specific time – increases. In California, solar curtailments have exceeded 10% of generation and are rising each year.<sup>4</sup> In Australia, curtailment of renewables has exceeded 6% in recent years.<sup>5</sup> Energy storage added to a solar asset can capture the curtailed energy and shift it to a time period when it is needed, rather than let it go unused.

Consider if your solar asset will be in a region with solar penetration exceeding 10% of local energy generation or subject to transmission and distribution system constraints that will limit deliverability of the plant’s generation. For solar assets with high curtailment risk, storage can alter the revenue outlook, capturing otherwise curtailed energy with zero or negative value and delivering it during high demand periods when the value of the energy is high.

For DC-coupled Solar + Storage assets, energy storage can also reduce energy clipping (see Figure 1). Clipping occurs when the DC power of a solar asset exceeds the input capabilities of the inverter. Solar assets are typically oversized compared to the inverter with an inverter load ratio (ILR)<sup>6</sup> of 1.3 to 1.5 for standalone systems.

With a DC-coupled configuration, energy storage can absorb the excess DC solar generation before it reaches

the inverter, storing it for later use. As a result, DC-coupled systems are often highly oversized (e.g., DC/AC ratios with an ILR between 2.3 and 2.7), allowing the storage asset to capture clipped energy for peak use (see Figure 2).

**FIGURE 2.** Illustrative Internal Rate of Return (IRR) and Excess Clipped Solar Delivered for a 100 MW<sub>AC</sub> Solar DC-coupled with a 100 MW/4-hour energy storage at different ILRs.

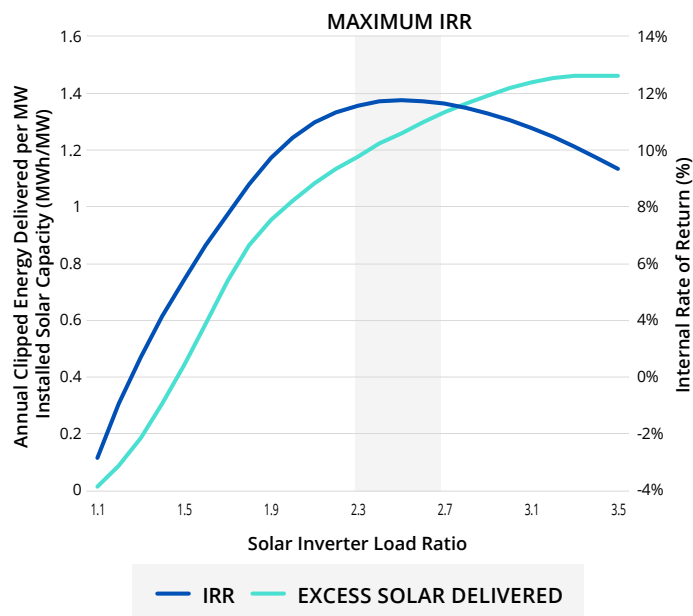

AC and DC-coupled solutions must ensure they have advanced digital intelligence to meet the demands of the grid. Beyond hardware configuration, digital software

4 GTM, California Renewables Curtailments Surge as Coronavirus Cuts Energy Demand, April 2, 2020, <https://www.greentechmedia.com/articles/read/california-renewable-curtailments-spike-as-coronavirus-reduces-demand>.  
 5 PV Magazine, Solar and wind set new output record even as curtailment continues to bite, February 12, 2020, <https://www.pv-magazine-australia.com/2020/02/12/solar-and-wind-set-new-output-record-even-as-curtailment-continues-to-bite/>.  
 6 The inverter load ratio (ILR) is the solar DC (MW capacity of the solar panels) to AC (MW output capacity of the solar inverters) ratio.

solutions are an essential ingredient to maximizing generation output and minimizing the impacts of solar curtailment or clipping. For example, DC-coupled asset controls with PV-specific modes including scheduled dispatch (maintain a constant inverter power output across both assets), export limiting (set a maximum inverter output across both assets) and directed charge (prioritizing charging of the storage asset from the PV) minimize the impacts of clipping and support revenue stacking across multiple value streams.

Asset owners must evaluate the risk of curtailment and the economic tradeoffs of capturing clipped energy compared to the additional cost of solar oversizing. Our previous white paper, “[The Economics and Technical Considerations of Solar + Storage](#)” provides a detailed guide to sizing a DC-coupled system.

An AC-coupled solution is capable of reducing curtailment and extending solar generation into the evening but is not capable of capturing energy lost due to inverter clipping. With up to 50% as much solar generation put onto the grid through the same interconnection, if the primary value driver of the Solar + Storage solution is maximizing

the output of the solar PV, DC-coupled is likely to be the superior configuration.

## STEP 2: REDUCE RISK EXPOSURE

For asset managers with requirements to serve load or meet contractual obligations for delivered energy, adding energy storage to a solar asset is similar to purchasing a financial hedge with the added value of real-time operational control and value stacking (e.g., from Value Streams 1 to 5). Energy storage can reduce an array of risks inherent to solar production, including price, volume, and shape risk (see Figure 3). Asset managers should consider whether the reduction in these risk types improves their ability to meet obligations with minimized merchant exposure.

Solar is an intermittent resource, producing energy only when the sun is available, regardless of market prices. **Price risk**, due to low electricity prices during solar hours, can be mitigated by charging an energy storage asset during low-price periods and discharging it during high-price periods.

Energy storage is highly adept at mitigating the risk from a potential mismatch between the contract generation profile

FIGURE 3. Depictions of Price, Shape, and Volume Risk for a Fixed Volume 12-hour Block PPA.

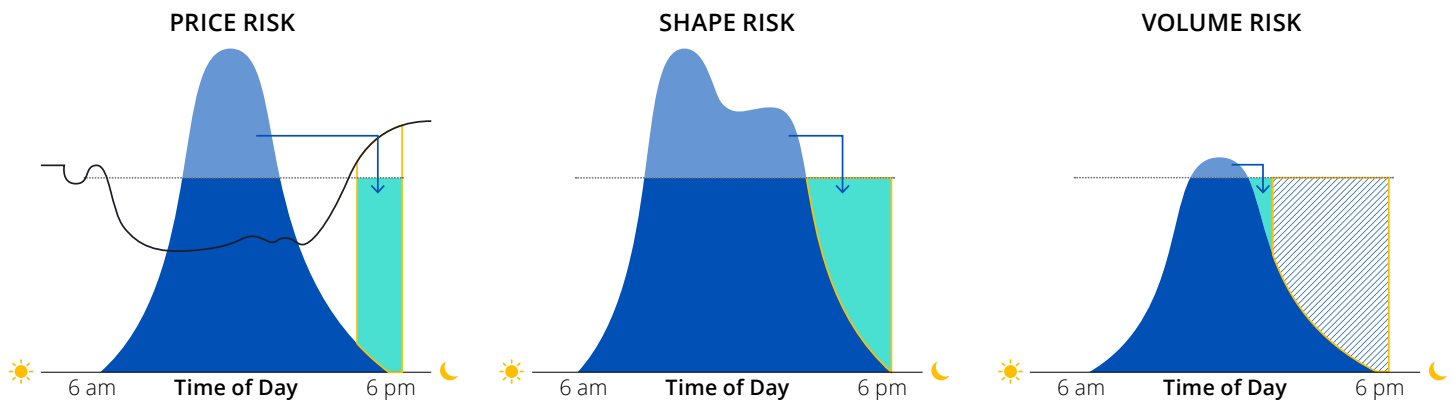

A mismatch between market prices and solar generation creates Price Risk. Energy storage can shift generation to high priced periods to offset merchant risk exposure.

Solar generation profile is determined by available solar resources, which may not fit the PPA or load obligations, creating Shape Risk. Energy storage can shift generation to meet contractual and reliability obligations, limiting exposure to market volatility.

When solar generation is below average, asset owners may be exposed to Volume Risk – under production compared to obligations. Energy storage charged from the grid during low price periods can be discharged during high-risk, high priced periods to offset low volume.

—	.....	—	■	■	■	///
Market Prices	Storage Capacity	Market Risk Exposure	Solar PV to Storage	Storage PV to Grid	Solar to Grid During High Prices	Grid-Charged Storage Discharged to Offset Low PV Generation



# Percent of Perfect Foresight

Percent of Perfect Foresight (PoP) allows asset owners to evaluate the performance of their digital bidding optimization engine. PoP compares the true operational revenue capture from an asset to the maximum revenue capture had the asset had perfect insight into future market prices (i.e., “perfect foresight”). Based on historical analysis, PoP equals the operational revenue capture scenario divided by the perfect foresight revenue capture scenario.

and the asset generation profile, or **shape risk**. Energy storage can smooth the generation profile throughout the day by charging and discharging captured solar energy and extend the profile by providing evening capacity as the sun sets. By eliminating the delta between the contracted energy requirements and the asset generation output, storage helps mitigate its exposure to volatile wholesale market prices.

Lastly, storage can also offset **volume risk** – where renewable energy production is insufficient to meet contractual obligations – by charging from the grid during low-price periods and discharging during high price periods to meet PPA requirements. Again, the co-located energy storage asset serves as an insurance policy, limiting the asset’s exposure to wholesale market volatility due to volume risk.

### STEP 3: DIGITAL OPTIMIZATION TO CAPTURE FULL BENEFITS

Solar + Storage assets’ value is not limited to time-shifting solar generation into the evening peak. In many competitive markets, co-located assets are able and eligible to provide ancillary services and balancing services.<sup>7</sup> As a result, assets bidding into wholesale and ancillary services markets have hundreds of thousands of decisions to make each hour. Digital intelligence designed specifically for the parameters of a Solar + Storage system is required to maximize revenue capture by optimizing asset managers’ real-time decision making. Advanced algorithms driven by artificial intelligence have the potential to optimize a Solar + Storage resource, prioritizing how and when the storage system charges and discharges alongside the solar output. Asset owners planning to participate in merchant trading and energy arbitrage should evaluate technology solutions designed to co-optimize system value, with scheduled dispatch, export limits, directed charge, and the ability to stack multiple grid services.

Furthermore, algorithmic bidding platforms have been proven to provide uplift for standalone storage and asset revenues of 40-50% over manual trading (i.e., revenue uplift), reaching 95 Percent of Perfect Foresight (PoP) revenues (see Figure 4).<sup>8</sup> Applying the same automated bidding techniques, taking into consideration the technical and contractual constraints of a Solar + Storage asset, has the potential to drive significant revenue uplift, co-optimizing the energy storage and PV resources in real time.

With algorithmic bidding software already maximizing the

value of standalone storage and renewable energy assets in the California CAISO wholesale electricity market and the Australian National Electricity Market (NEM), advanced bidding platforms are already proving a game-changing resource for asset managers.

**FIGURE 4.** Illustrative Market Revenue (\$/kW) by Bidding Strategy for a 50MW/200MWh standalone energy storage asset.

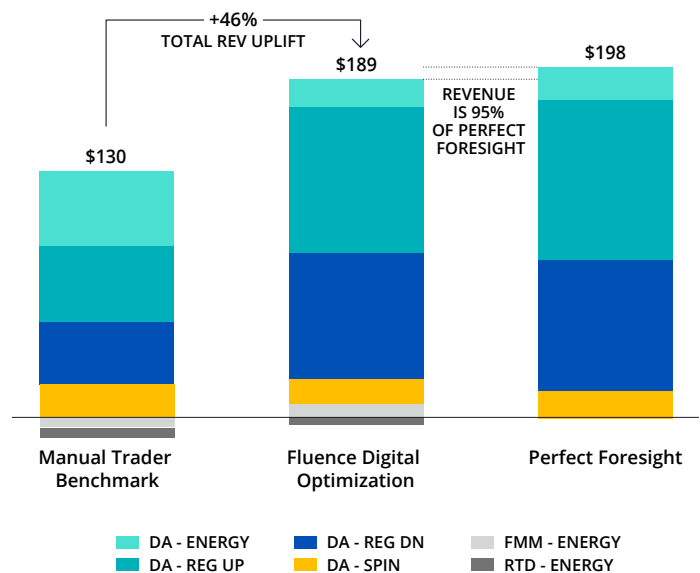

*Data Based on Fluence Digital trading platform performance for standalone energy storage asset in the CAISO electricity markets. PoP is calculated by comparing the capabilities of the digital bidding solution to the perfect foresight scenario. Legend Definitions: DA – Day-Ahead Market; FMM – Five Minute Market; RTD – Real-time Market*

While both AC- and DC-coupled Solar + Storage assets are capable of offering ancillary services, AC-coupling increases asset flexibility, a valuable proposition if merchant trading is the primary value stream. With separate inverters, and at times separate points of interconnection, AC-coupled solar PV and storage systems can be optimized at any

<sup>7</sup> Ongoing regulatory proceedings will have an impact on the market participation model of Solar + Storage (and other co-located) assets. See ongoing proceedings in California and Australia among others.

<sup>8</sup> How to maximize your battery’s value in California, Fluence Blog

given point in time, regardless of the other asset's decision-making process. For example, an AC-coupled storage asset has greater flexibility to provide real-time balancing services during the day when solar PV generation is high. By comparison, a similarly sized DC-coupled storage asset may be limited by the capacity of the shared inverter.

#### **STEP 4: INTEGRATE RENEWABLES AND MEET INTERCONNECTION REQUIREMENTS**

Solar energy is a variable resource in two ways: predictable variability and unpredictable variability. Checklist item 1 above considers the predictable variability of solar generation – a familiar generation curve where the sun rises every morning and sets every evening. By contrast, this action utilizes energy storage to minimize the unpredictable variability of solar generation – how production changes throughout the day due to changing weather conditions producing differing amounts of cloud cover. Energy storage provides stabilizing functions like generation smoothing and ramp limiting that keep renewable output stable and help avoid curtailment.

In certain regions and markets, the unpredictable variability of Solar + Storage can also potentially affect the stability on the distribution or transmission system, leading system operators to adopt interconnection requirements for solar such as ramping controls. Under such requirements, failure to provide stable generation output would result in the rejection of an interconnection request. Such requirements are common on island grid systems, such as those in the Caribbean. Additionally, grids experiencing rapid growth

in variable renewable energy (VRE) generation, such as in India, will also impose similar requirements or require expensive transmission and distribution system upgrades to accommodate new VRE resources.

Asset managers can use energy storage to stabilize output, ensure their solar assets meet grid requirements, and reduce interconnection costs.

#### **STEP 5: MEET POLICY AND REGULATORY REQUIREMENTS TO CAPTURE ADDITIONAL VALUE**

As the energy transition gains momentum globally, new incentives will increasingly emerge across different markets. Capitalizing on available public policy incentives can enhance the already strong business case for energy storage. In certain instances, incentive regulations and requirements may be written in a way to influence the configuration, operation, and value of an energy storage asset seeking to qualify.

For example, in the United States, an investment tax credit – a credit for the capital costs of an asset on a business's federal taxes – is available for solar energy developments. Under current requirements, an energy storage asset can only receive the tax incentive if it is charged at least 75% of the time by a solar asset. For simplicity, many assets are DC-connected to ensure qualification of the storage asset. As such, DC-coupled solutions are the most obvious and clear way to comply with such operational requirements, increasing demand for the configuration in U.S. power markets.

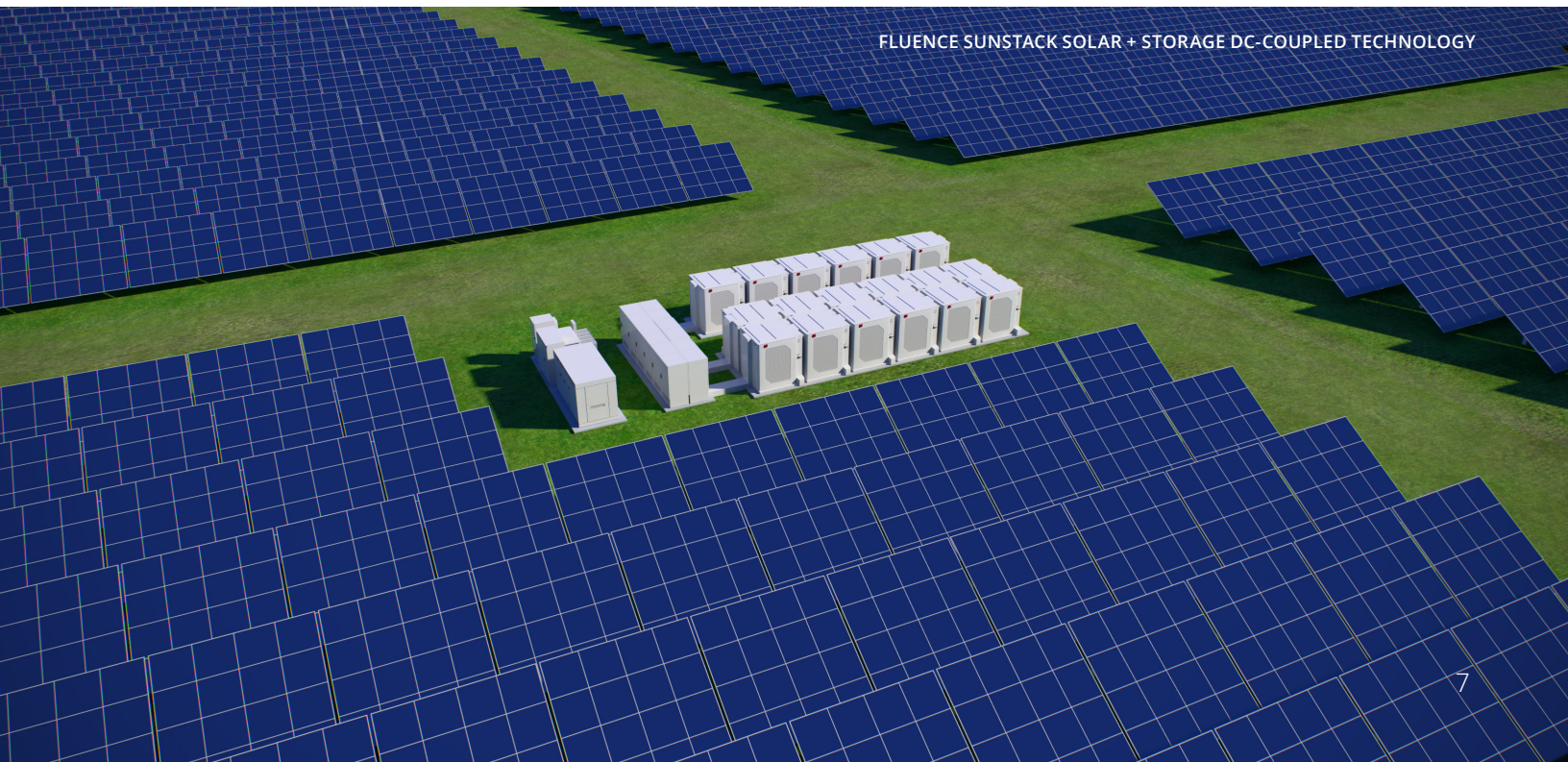

FLUENCE SUNSTACK SOLAR + STORAGE DC-COUPLED TECHNOLOGY



# Solar + Storage Playing Different Roles



*Pictured: Similar Enel solar project in MN, USA*

## ENEL AZURE SKY SOLAR + STORAGE, USA

Located in the ERCOT market in Texas, Enel Green Power's Azure Sky Solar + Storage project consists of a 284 MW<sub>DC</sub> solar PV asset and an 81 MW/1.5-hour energy storage asset set to come online in the summer of 2021.

### Primary Value Streams:

- Merchant Trading – energy and grid services (Value Stream 3)
- Energy shifting (Value Stream 1)

Within ERCOT's current market structure, the energy storage asset can drive market value through arbitrage in the wholesale and grid services markets. A short duration, AC-coupled configuration allows the asset to maximize flexibility while minimizing costs.



## AES GENER ANDES SOLAR II B, CHILE

AES Gener's Andes Solar II B Solar + Storage project will include 180 MW of solar DC-coupled with a 112 MW/5-hour energy storage asset coming online in early 2022.

### Primary Value Streams:

- Risk mitigation (Value Stream 2)
- Energy shifting (Value Stream 1)

AES Gener provides contracted firm energy to its industrial customers in Chile. The Solar + Storage asset reduces AES Gener's wholesale market volatility exposure by providing solar energy throughout the evening peak. The DC-coupled system maximizes the solar energy delivered to the grid.

## The Right Solutions for the Right Situations

Solar + Storage is a linchpin of the energy transition, providing cost-effective, reliable energy; its importance is reflected in the continual announcements of projects in new markets and their record-breaking sizes. Asset owners and developers need to consider the broad range of value co-located assets can provide or they risk leaving money on the table. Every project will require unique analysis and evaluation – every project will not always be able to capture all five value streams.

Depending on the project, market, and objectives of the Solar + Storage system, asset owners need to weigh the tradeoffs across different value streams, and system designs to maximize value creation.

With more than 13 years of experience developing new applications and driving energy storage innovations, Fluence offers modular and scalable hardware with digital intelligence to maximize Solar + Storage revenues while driving down costs.



## ABOUT FLUENCE

Fluence (Nasdaq: FLNC) is a global market leader in energy storage products and services, and digital applications for renewables and storage. With a presence in 30 global markets, Fluence provides an ecosystem of offerings to drive the clean energy transition, including modular, scalable energy storage products, comprehensive service offerings, and the Fluence IQ Platform, which delivers AI-enabled digital applications for managing and optimizing renewables and storage from any provider. The company is transforming the way we power our world by helping customers create more resilient and sustainable electric grids.

**To learn more about Fluence, please visit: [fluenceenergy.com](https://fluenceenergy.com).**